

Pressure Reducing Valve

Model FP 420/ZSJF

The Model FP 420 Pressure Reducing Valve is a hydraulically self operated, diaphragm actuated pressure control valve.

The FP 420 is designed to reduce a high upstream pressure to a precise and stable lower preset pressure downstream.

The preset downstream pressure will be held regardless of fluctuating demand or varying upstream pressure, including static or no flow conditions.

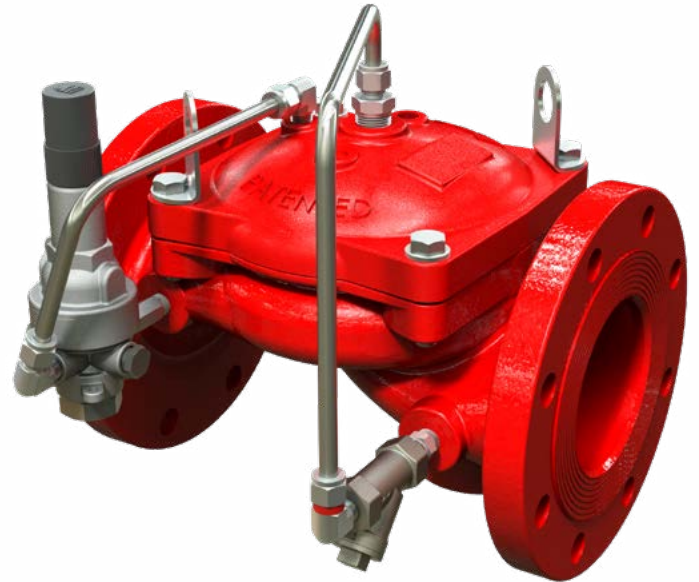

(for Illustration Only)

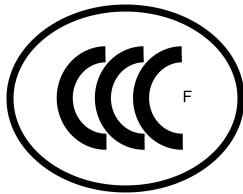

Features and Benefits

- **Advanced Elastomeric Globe type** – Low pressure loss
- **One-piece molded elastomeric moving part** – No maintenance required
- **Simple design** – Cost effective
- **Factory pre-assembled trim** – Full factory testing
- **In-line serviceable** – Minimal down time

Optional Features

- **Large control filter** (code: F)
- **Seawater service**
- **Valve Position Single/Double Limit Switches**

Note: For more optional features see ordering guide or contact BERMAD.

Typical Applications

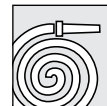

Hose station feeds

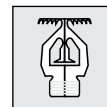

Sprinkler systems with overpressure

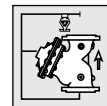

Deluge systems with overpressure

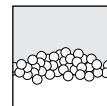

Foam systems

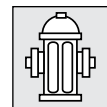

Fire hydrant water supply

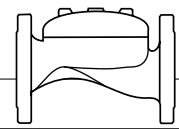

Operation

The BERMAD Model FP 420, pilot operated pressure reducing valve automatically and accurately reduces upstream water pressure to a specific, adjustable value. The FP 420 operates under both flowing and non-flowing (static) conditions. The Pressure Reducing Pilot [1] senses downstream pressure [2] and modulates the main valve [3] to maintain the constant downstream pressure.

In no-flow static conditions, should the downstream pressure start rising above pilot setting, the pilot closes, shutting the main valve drip-tight [4] maintaining the allowable downstream pressure.

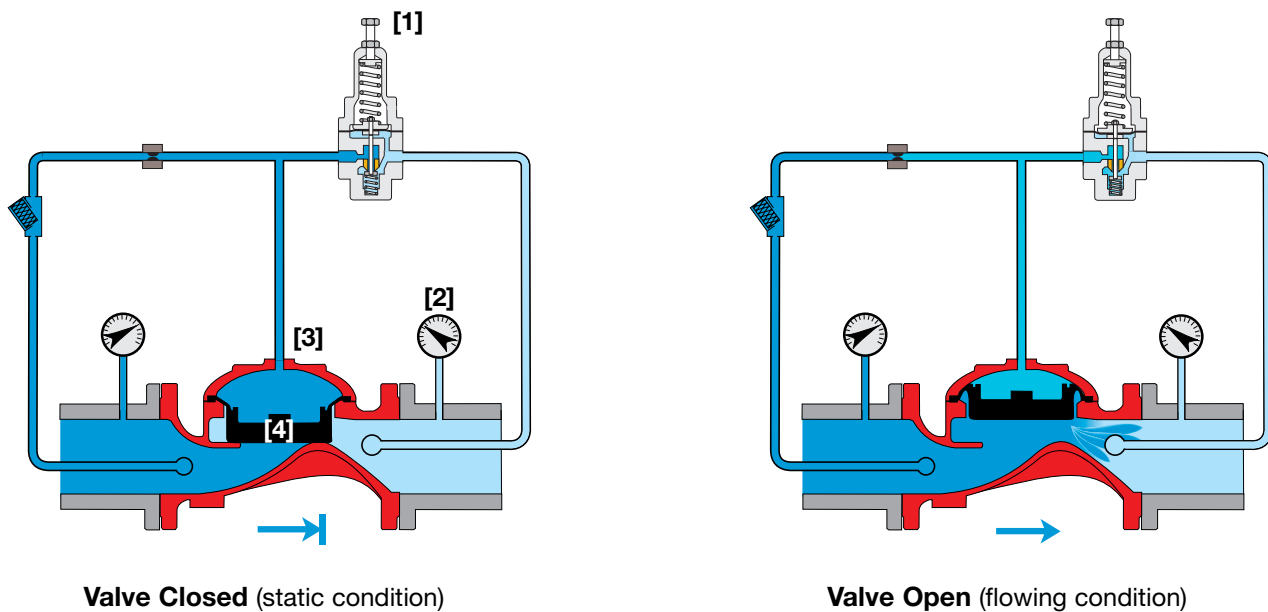

Engineer Specifications

The pressure reducing valve shall eliminate downstream over-pressure, maintaining a constant downstream delivery pressure, regardless of varying pressures and/or flows.

The main valve shall be an elastomeric type globe valve with a rolling-diaphragm.

Valve actuation shall be accomplished by a fully peripherally supported, one-piece balanced rolling-diaphragm, vulcanized with a rugged radial seal disk. The diaphragm assembly shall be the only moving part.

The valve shall have an **unobstructed flow path**, with no stem guide or **supporting ribs**.

The valve shall have a removable cover for quick in-line service enabling all necessary inspection and servicing. The control trim shall be supplied as an assembly, pre-assembled and hydraulically tested at an ISO 9000 and 9001 certified factory.

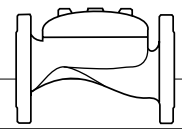

Typical Installations

Standard Pressure Reducing System

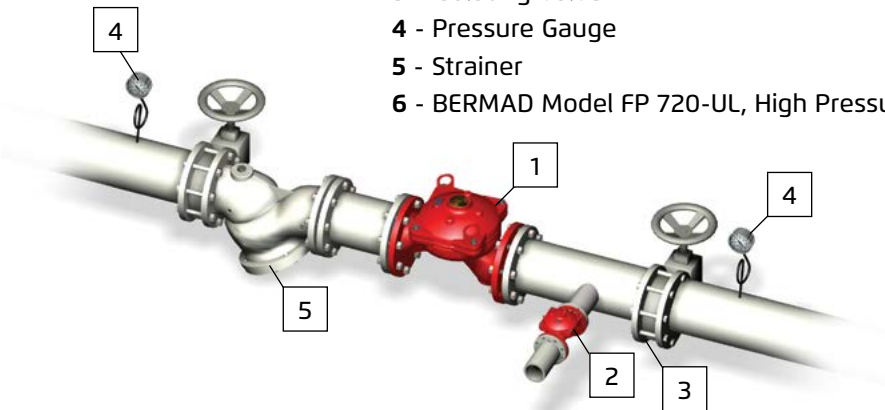

Parallel Pressure Reducing System

- Wide flow range
- Redundant safety
- Serviceable with zero down time

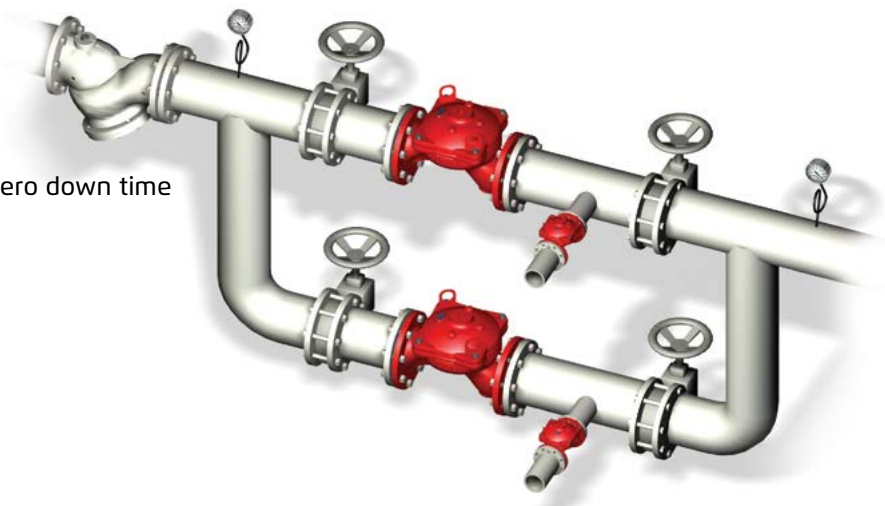

Two-Stage Pressure Reducing System

- High pressure differential
- Added reduced pressure zone protection

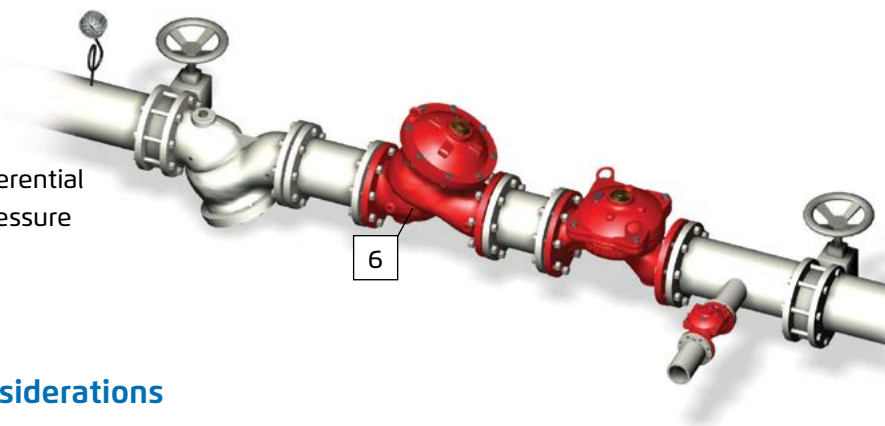

System Components

- 1 - BERMAD Model FP 420
- 2 - BERMAD Model FP-430-UF Pressure Relief Valve
- 3 - Isolating Valve
- 4 - Pressure Gauge
- 5 - Strainer
- 6 - BERMAD Model FP 720-UL, High Pressure Reducing Valve

Installation Considerations

- Allow enough room around the valve assembly for any future maintenance.
- Install isolating valves upstream and downstream of the system.
- Install the valve horizontally with the cover facing up (consult Bermad for other configurations).
- Install a relief valve (recommended: BERMAD Model FP 430-UF) of the appropriate size on the downstream side of the FP 420, as required by NFPA-20 standard.
- Install a pressure gauge on each side of the system.

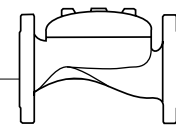

Technical Data

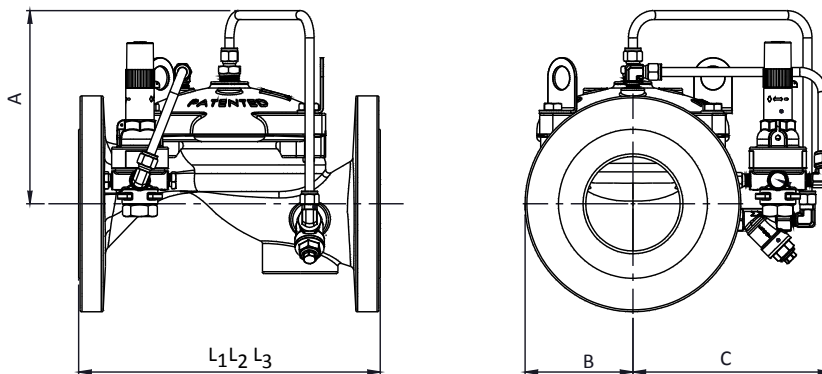

Size	2"		2½"		3"		4"		6"		8"		10"		12"		
	mm	inch	mm	inch	mm	inch	mm	inch	mm	inch	mm	inch	mm	inch	mm	inch	
Dimensions	L ₁ ⁽¹⁾	205	8.1	205	8.1	257	10.1	320	12.6	415	16.3	500	19.7	605	23.8	725	28.6
	L ₂ ⁽²⁾	205	7.1	210	8.3	250	10.0	320	12.5	415	16.3	500	19.7	N/A	N/A	N/A	N/A
	L ₃ ⁽³⁾	180	7.1	210	8.3	N/A	N/A	N/A	N/A	N/A	N/A	N/A	N/A	N/A	N/A	N/A	N/A
	A	155	6.1	167	6.6	185	7.3	205	8.1	309	12.2	350	13.8	354	13.9	455	17.9
	B	78	3.1	89	3.5	100	3.9	115	4.5	157	6.2	174	6.9	183	7.2	305	12.0
C	169	6.7	169	6.7	197	7.8	210	8.3	278	10.9	296	11.7	296	11.7	360	14.2	

- Notes:**
- L₁ is for flanged valves.
 - L₂ is for grooved end connections (Ductile Iron Only).
 - L₃ is for threaded NPT or ISO-7-Rp.
 - Data for the trim envelope or extent dimensions, may vary with specific component positioning. Allow a tolerance of at least 10%.
 - Provide adequate space around valve for future maintenance.

Connection Standard

- Flanged: ANSI B16.42 (Ductile Iron), B16.5 (Steel & Stainless Steel), B16.24 (Bronze)
- ISO PN16
- Threaded: NPT or ISO-7-Rp for 2, 2½ & 3"
- Grooved: ANSI/AWWA C606 for 2, 3, 4, 6 & 8"

Water Temperature

- 0.5 – 50°C (33 – 122°F)

Available Sizes

- Globe: 2, 2½, 3, 4, 6, 8, 10 & 12"

Pressure Rating

- Max. inlet: 17 bar (250 psi)
- Set: 2 - 11.5 bar (30 - 165 psi)
- Test : 25 bar (365 psi)

Approvals

- ABS
- Lloyd's Registered
- CCCF Approved: 2, 2½, 3, 4, 6, 8, 10 & 12" for 1.6 MPa/16 bar

Manufacturers Standard Materials

Main valve body and cover

- Ductile Iron ASTM A-536

Main valve internals

- Stainless Steel & Elastomer

Control Trim System

- Brass control components/accessories
- Stainless Steel 316 tubing & fittings

Elastomers

- Polyamide fabric reinforced Polyisoprene, NR

Coating

- Electrostatic Powder Coating Polyester, Red (RAL 3002)

Optional Materials

Main valve body

- Carbon Steel ASTM A-216 WCB
- Stainless Steel 316
- Ni-Al-Bronze ASTM B-148

Control Trim

- Stainless Steel 316
- Monel® and Al-Bronze
- Hastelloy C-276

Elastomers

- NBR
- EPDM

Coating

- High Build Epoxy Fusion-Bonded with UV Protection, Anti-Corrosion

*For more options refer to Ordering Guide or contact BERMAD

