

# WP-F Dynamic

## Protection Sieve DN 40 ... DN 200



### Special Features

---

- Small head loss
- Sieve elements for use with all WP-Dynamic-bodies
- Identical sieve elements for DN 40...65 and DN 80 + 100
- Stainless steel sieve element
- Sieve element easy to remove for cleaning
- Powder coated body for maximum corrosion protection

### Application

---

- The protection sieve will be installed to protect the water meter from damage
- The heavy duty sieve element retains any large particles
- Cleaning of pipes after maintenance or rupture in the pipe
- Max. working pressure 16 bar
- Max. water temperature 50 °C

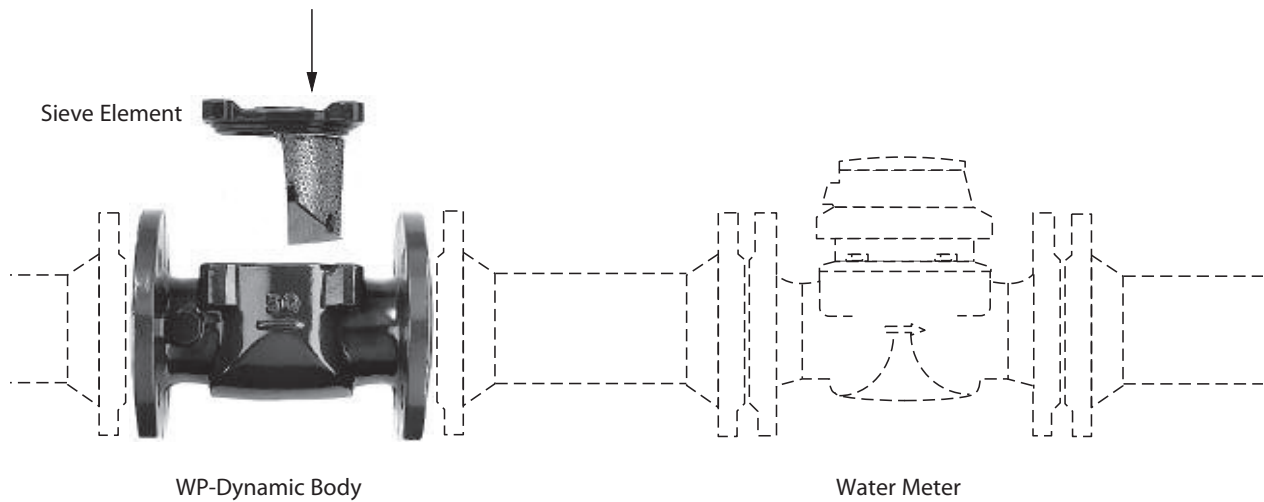

## Dimension Picture

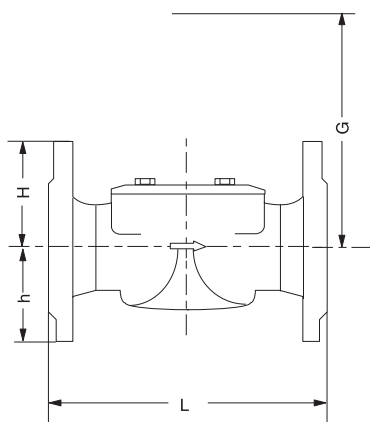

## Dimensions and Weights

DN	L (mm)	h (mm)	Sieve elem.	H (mm)	G (mm)	Weight (kg)
40	220	69	RV 3-4 DIN 24041	75	140	7.1
50	200	73		85	140	7.7
65	200	85		95	140	9.4
80	225	95		100	200	12.9
100	250	105		110	200	15.9
125	250	125		125	220	19.5
150	300	135		145	285	34.0
200	350	162		170	370	50.0

## Materials

Body:	Cast iron
Cover flange:	Cast iron
Sieve element:	Stainless steel
Bolts:	Stainless steel

## Order Text

Protection sieve complete:  
 Specification: Sieve complete  
 Nominal Diameter: DN .....

Sieve element:  
 Specification: Sieve element  
 for Nominal Diameter: DN .....

## Typical Head Loss Curve\*)

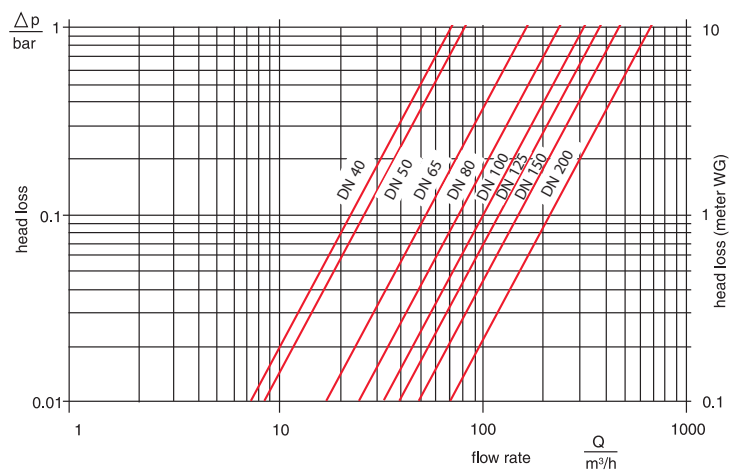

\*) with clean sieve element

Bermad Water Technologies  
 Ph (03) 9464 5421  
[www.bermad.com.au](http://www.bermad.com.au)

## WP-F Dynamic