

PRODUCT DATA SHEET

DAB-251NXTP • 808425



BRAND

DAB
WATER • TECHNOLOGY

PRODUCT DETAILS

DAB pressure system with electronic pump controller. The pump is a self-priming surface mounted jet pump and has a suction capability of up to 8m.

APPLICATIONS

- Domestic installations where a suction lift is required
- Pressure boosting, irrigation and wash down
- Designed for pumping from tanks, rivers and dams.

FEATURES

- Run dry protection to prevent pump damage
- The nXt controller has an in-built check valve to prevent water back-flow through the pump
- Self priming centrifugal pump with excellent suction capability
- 240V single phase TEFC motor with in-built auto reset thermal overload to prevent pump from damage
- A pressure tank is recommended

TECHNICAL DATA

MATERIALS IN CONTACT WITH DRINKING WATER

PUMP

PUMP BODY	GJL 200 Cast Iron
IMPELLER	Glass reinforced Noryl
JET, VENTURI, DIFFUSER	Glass reinforced Noryl
MECHANICAL SEAL	Carbon Ceramic Nitrile
O RINGS	Nitrile
CONTROLLER	
CONTROLLER BODY	Glass reinforced Noryl
DIAPHRAGM	Butyl (TPV)
PORTS, NRV	Glass reinforced Noryl
SPRING	Stainless Steel
PRESSURE SENSOR	Brass OT58

SPECIFICATIONS

RATED POWER (KW)	1.85 (2.5hp)
MAX. FLOW [LPM]	120
MAX. HEAD [M]	62
PORTS	32mm x 25mm (1-1/4"x1")BSP
START PRESSURE (BAR)	2.2
STOP PRESSURE (BAR)	No Flow
VOLTS (V)	240
CARTON DIMENSIONS	800mm L x 250mm W x 360mm H
WEIGHT (KG)	36.5

CURVE

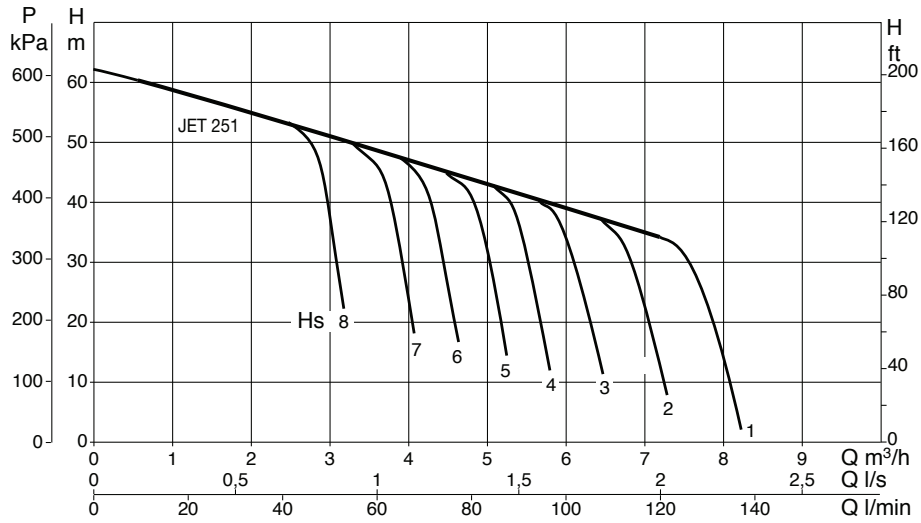

DIMENSIONS

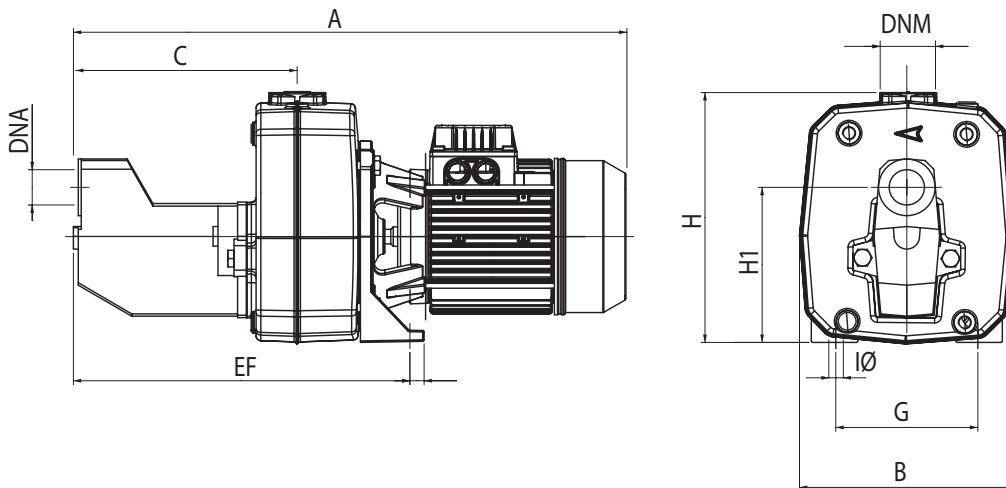

MODEL	A	B	C	E	F	G	I Ø	H	H1	DNA GAS	DNM GAS
DAB-251 M	632	210	221	350	20	145	11	255	158	1¼"	1"

WARRANTY / CERTIFICATIONS

