

HS Series



Tested in compliance with
AS/NZS 4020
for use in contact with safe drinking water



Model Numbers:
HS50-06T, HS60-08T

ROBUST AND COMPACT FOUR STAGE HOME PRESSURE SYSTEM

APPLICATION

Ideal for pumping clean, non-volatile liquids without fibres or solids in such applications as household water supply, irrigation, water transfer, washing systems and pressure boosting.

FEATURES & BENEFITS

The HS Series pressure systems consist of an HS pump fitted with a Torrium2 controller. The Torrium2 is supplied connected electrically to the HS pump motor for:

- Easy non-tradesmen installation and assembly
- Positive safety under varied weather conditions

The combination of the high pressures supplied by the multistage HS pump and constant flow control provided by the Torrium2 enables consumers to enjoy the benefits of a strong comfortable shower from a pump that does not cycle plus the reliability of adaptive technology.

The complete HP Pressure System is compact and quiet providing for:

- Easy installation, especially where space is at a premium
- Non-intrusive operation, for consumer enjoyment

All parts of the entire system that are in contact with the water are manufactured from safe, corrosion resistant materials for:

- Consumer confidence that their water supply will be as good coming out as it was going into the system
- Ability to use the HS pressure system on a variety of water qualities

- Compliance with the strict requirements of ISO 9001.2000 quality standards ensures consistency of quality of the system
- Air purging valve for easy installation and priming

Torrium2 CONTROLLER

For more information visit daveywater.com

PUMP

High efficiency, quiet "half blind" impeller in 4 stage design in two flow rate ranges for:

- More pressure in home outlets
- Choice of performance options to suit most homes
- Quieter household environment
- Improved waterway clearances to reduce impeller blockages

Impeller have dual shaft flats for positive drive and long life, especially important for household pressure systems where pumps are required to stop and start many times during their life.

Patented floating impeller neck rings help improve efficiency and reduce hydraulic noise providing better performance with less noise.



Making water work for you
www.dowdens.com.au

MACKAY (Head Office)
9-15 Industrial St, Mackay Qld 4740
Phone: 07 4969 4949
info@dowdens.com.au

ROCKHAMPTON
4/415 Yaamba Rd, Rockhampton Qld 4701
Phone: 07 4923 6969
info@dowdens.com.au

PROSERPINE
2 Mann St, Proserpine Qld 4800
Phone 07 4969 4940
info@dowdens.com.au

Home Pressure Systems

304 stainless steel casing, pump shaft and diffuser baffle returns provide long life and ability to withstand pressure variations.

Special in-built air purging valve helps remove air from the pump and suction during original priming and also during normal operation, thus:

- Makes original installation quicker and easier
- Reduces the chance of pump operating in a partial prime condition

High quality, low-drag mechanical shaft seal for long life and reliable starting.

MOTOR

The Davey manufactured TEFC motor has an IP55 enclosure providing:

- Excellent corrosion resistance
- High levels of resistance to dust and rain

All HS pump motors are class F insulation rating and have higher than normal ambient temperature ratings of 50°C, providing for longer life, improved tolerance to voltage variations and peace of mind, even on the hottest days.

Permanently split P2 'fail safe' capacitor design:

- Reliable starting even in low voltage circumstances.
- Superior frequent starting performance
- Single phase motors are protected against both high operating temperatures and high current by a built in, automatically resetting thermal overload
- Double contact C3-HTG sealed bearings for quieter running and longer life
- Corrosion resistant feet on motor shell, include three point bolt-down facility
- Standard models are 220/240 volt, 50Hz, single phase. HS models in 60Hz 110/115 volt and 220/230 volt single phase available on request

OPERATING LIMITS	
Maximum system pressure*	700kPa
Capacities to	110 lpm
Maximum total head	50m
Maximum suction head	6m
Maximum ambient temperature	50°C
Maximum water temperature	50°C
Minimum water temperature	1°C

Torrium2 cut-in pressure is normally 80% of the pumps last shut-off head.

* Note: See high pressure operation note next page.

ELECTRICAL DATA		
Model	HS50-06T	HS60-08T
Supply Voltage	220-240V ±6%	
Supply frequency	50Hz	
Phase	Single	
Speed	2850rpm	
Full load current	3.8A	4.9A
Locked rotor current	12.0A	18.0A
Input power (P ₁)	0.89kW	1.1kW
Output power (P ₂)	0.6kW	0.76kW
Enclosure class	IP55	
Insulation class	Class F	
Starting	P.S.C.	

AS/NZS 3350.2.41-1997 Approval No. A/10059EA

Note: All performance at 240V 50Hz

MATERIALS OF CONSTRUCTION	
PART	MATERIAL
Pump	
Impellers	Glass filled polycarbonate
Lock nut	304 stainless steel
Pump casing	304 stainless steel
Pump backplate	304 stainless steel
Pump shaft	303 stainless steel
Neck rings	Polypropylene + teflon
Seal ring (stationary)	Ceramic
Seal ring (rotating)	Carbon (synthetic)
Seal spring	304 stainless steel
O-rings	Nitrile rubber
Stage body	Glass filled noryl
Priming plug	Glass filled noryl
Motor shell	Marine grade aluminium
Lantern/DE endshield	Marine grade aluminium
Shell and lantern finish	Baked polyester
Torrium2	
Housing	Glass fibre reinforced nylon
Pressure tank diaphragm	Santoprene 87
Pressure tank springs	Molybond coated tempered steel
Sensor plate	316 stainless steel
Inlet union	Glass fibre reinforced nylon
O-rings	Nitrile
Check valve poppet	Acetal
Check valve spring	304 stainless steel

TORRIUM2	
Voltage	110V-240V ±10%
Phase	Single
Hz	50 / 60
IP rating	56
Maximum load current	10A
Maximum motor size*	1.8kW
Surge protection	Varistor

*At 240V input

AS/NZS4020 CERTIFICATION

Davey's HS water pressure systems pumps including Torrium2 have been certified as AS/NZS4020 compliant.

The AS/NZS4020 Standard stipulates that products in contact with drinking water do not affect the taste of appearance of the water; do not support the growth of micro-organisms and do not release cytotoxic or mutagenic compounds or metals into the water.

INSTALLATION AND PRIMING

- Installations with suction lift require a good quality foot valve to avoid loss of prime - remove in-built check valve.
- To prime, fill pump body and suction line through priming plug hole located above suction inlet and replace plug.

Home Pressure Systems

DIMENSIONS (mm)

Model	A	B	C	D ₁	D ₂	E	F	G	H	I	Inlet	Outlet	Net Weight (kg)
HS50-06T	405	390	170	115	105	145	183	170	75	125	1 1/4" F	1" M	9.8
HS60-08T	430	390	170	115	105	145	208	170	75	125	1 1/4" F	1" M	11.3

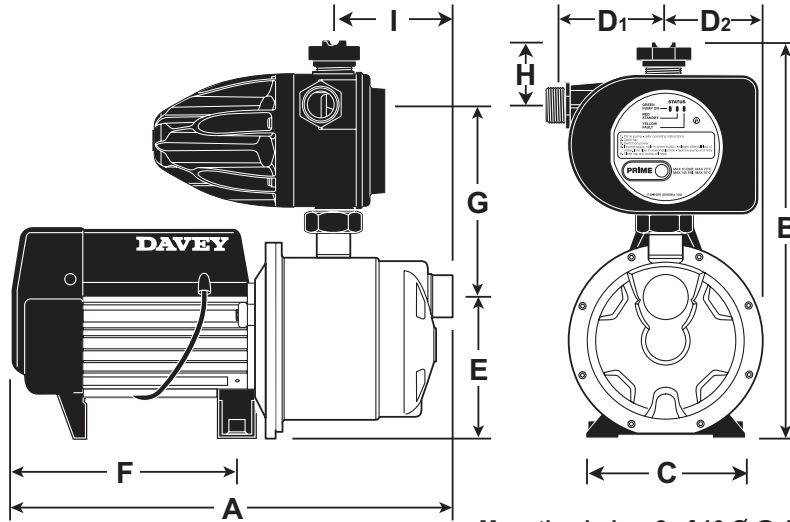

Mounting holes: 2 of 10 Ø @ 140 centres

HYDRAULIC PERFORMANCE

